

PRODUCT INFORMATION PACKET

Model No: 184TTTN16545

Catalog No: U1868

5 HP Severe Duty Motor, 3 phase, 1800 RPM, 230/460 V, 184TV Frame, TEAO
Low Voltage NEMA Cooling Tower Motors



Nameplate Specifications

Output HP	5 Hp	Output KW	3.7 kW
Frequency	60 Hz	Voltage	230/460 V
Current	12.4/6.2 A	Speed	1755 rpm
Service Factor	1.15	Phase	3
Efficiency	90.2 %	Power Factor	83.5
Duty	Continuous	Insulation Class	F
Design Code	B	KVA Code	J
Frame	184TV	Enclosure	Totally Enclosed Air Over
Thermal Protection	No	Ambient Temperature	40 °C
Drive End Bearing Size	6206	Opp Drive End Bearing Size	6206
UL	Recognized	CSA	Y
CE	N	IP Code	56

Technical Specifications

Electrical Type	Squirrel Cage Inverter Rated	Starting Method	Line Or Inverter
Poles	4	Rotation	Reversible
Resistance Main	2.62 Ohms	Mounting	Rigid base
Motor Orientation	Horizontal Or Up Or Down	Drive End Bearing	Ball
Opp Drive End Bearing	Ball	Frame Material	Cast Iron
Shaft Type	T	Overall Length	15.74 in
Frame Length	10.00 in	Shaft Diameter	1.125 in
Shaft Extension	2.85 in	Assembly/Box Mounting	F1/F2 CAPABLE
Outline Drawing	035670-1000	Connection Drawing	A-EE7308

This is an uncontrolled document once printed or downloaded and is subject to change without notice. Date Created:27/03/2020

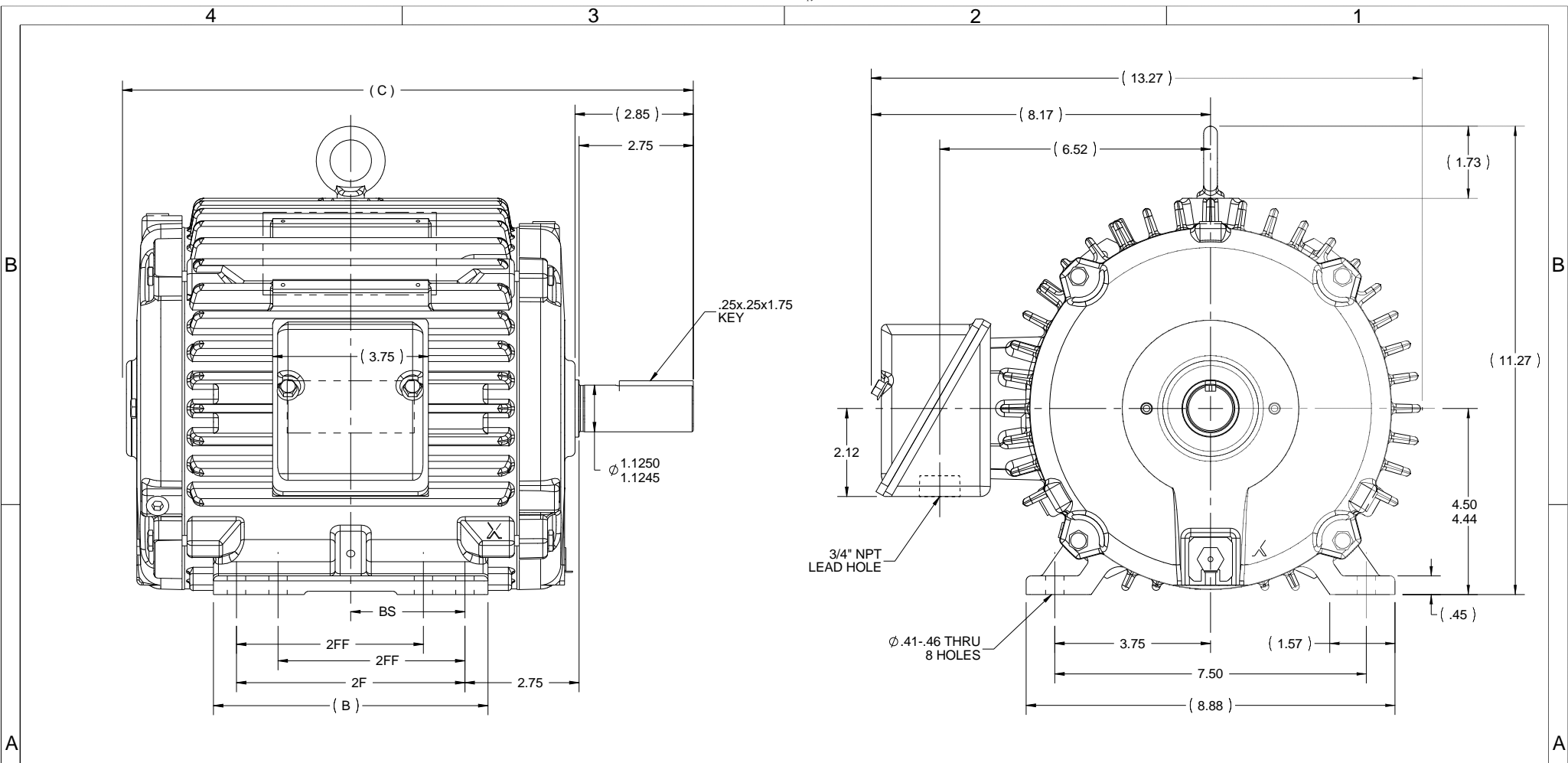

- NOTES:
 1. NAMEPLATE TO BE READ FROM CONDUIT BOX SIDE OF MOTOR.
 2. CONDUIT BOX CAN ROTATED IN 90° STEPS.
 3. CONDUIT BOX CAN BE MOUNTED ON OPPOSITE SIDE BY REMOVING BRACKETS AND TURNING FRAME 180°

DRAWING REVISION C	REVISION BY SS	DATE 05/31/16
ECO ECO-0101042	APPROVED BY GR	DATE 05/31/16
ECO DESCRIPTION TEMPLATE UPDATED.		
<small>COPYRIGHT REGAL BELOIT AMERICA, INC. ALL RIGHTS RESERVED. PROPRIETARY AND CONFIDENTIAL INFORMATION - THIS DOCUMENT IS THE PROPERTY OF REGAL BELOIT AMERICA, INC. ('OWNER') AND CONTAINS OWNER'S PROPRIETARY INFORMATION. ANY PERSON, CORPORATION OR OTHER FIRM RECEIVING IT IS DEEMED, BY RECEIVING IT, TO AGREE THAT IT, AND/OR ANY PART OF IT, SHALL NOT BE DISCLOSED TO ANY PERSON, CORPORATION OR OTHER ENTITY, DUPLICATED, AND/OR USED, EXCEPT AS EXPRESSLY APPROVED IN WRITING IN ADVANCE BY OWNER. THIS DOCUMENT SHALL BE RETURNED TO OWNER UPON REQUEST. IT MAY BE SUBJECT TO CERTAIN RESTRICTIONS UNDER APPLICABLE EXPORT CONTROL LAWS AND REGULATIONS.</small>		

TOLERANCES UNLESS OTHERWISE SPECIFIED:			
DEC.	INCH	mm	ANGLE
.X	+0.1	[+2.5]	±0.5°
.XX	+0.01	[+0.25]	
.XXX	+0.005	[±0.127]	
.XXXX	+0.0005	[±0.0127]	
REMOVE BURRS & BREAK SHARP EDGES: .003/.015 [.076/.381] X 45°			
CORNER FILLETS: R.02 [.51]			
MACHINED SURFACES: 125/3.2			
mm SHOWN IN [BRACKETS]			

DRAWN BY TJW
DATE 3/25/2008
APPROVED BY SW
DATE 3/26/2008
REFERENCE
THIRD ANGLE PROJECTION

REGAL™ Regal Beloit America, Inc.

DESCRIPTION
OUTLINE
180 FR. - CAST C'BOX

MATERIAL
PROCESS/FINISH

SIZE
B

DRAWING NUMBER
035670

SHEET
1 OF 1

1000	182/184	15.74	8.61	7.50	5.50	3.75
800	182/184	13.74	6.61	5.50	4.50	2.75
DASH	FRAME	C	B	2F	2FF	BS

EE7308

THREE PHASE
DUAL VOLTAGE MOTOR



VIEW OF TERMINAL END

REF.
WINDING DIAGRAM

T8Y, T2Y, T2BL, T4BX, T2EC, T2G
T6BZ, T2B, T6BL, T4AV, T6B, T4B

OPTIONAL CORD
CONNECTION

L1 — WHITE
L2 — RED
L3 — BLACK

NO.	REVISION	BY & DATE	CHK	ANG	TOLERANCES UNLESS SPECIFIED		FINISH	DRAWN RM 11/20/1990				
					DEC.	INCHES						
5	CHG TO REGAL LOGO	SL 09/10/2015	AB					CHK ML 11/21/1990				
4	REVISED IEC NOTATIONS	MSG 11/15/2011	CMN	.X	±.1			APPD SAS 04/24/2003				
3	ADDED IEC NOTATIONS... (U1), (V1) ETC. MU95194	MSG 5/10/2010	MJS	.XX	±.02		TITLE CONNECTION DIAGRAM	SCALE 1=1				
2	ADDED THE OPTIONAL CORD CONNECTION MU46318	RDH 04/24/2003	DRS	.XXX	±.005		3Ø - DUAL VOLTAGE MOTOR	REF				
1	REDRAWN	RM 11/20/1990		.XXXX	±.0005		MAT'L.	FMF				
					±7'30"			PREV				
THIS DRAWING IN DESIGN AND DETAIL IS OUR PROPERTY AND MUST NOT BE USED EXCEPT IN CONNECTION WITH OUR WORK ALL RIGHTS OF DESIGN AND INVENTION ARE RESERVED THIS IS AN ELECTRONICALLY GENERATED DOCUMENT - DO NOT SCALE THIS PRINT							RFP	CAD FILE ee7308	SIZE A	DRAWING NO. EE7308	PAGE OF 5	REV. 5
							DIST WP					



** Subject to change without notice.

Data Sheet

1841TTN16545



Submission
Data @ 460 V

Date: 6/20/2017

Customer:
Attention:
Submitted by: FAREEDA DUDEKULA

Motor Load Data

Load	0%	25%	50%	75%	100%	115%	125%	LR
Current (Amps)	2.80	3.0	3.8	5.0	6.2	7.2	7.8	46.0
Torque (ft-lb)	0.00	3.7	7.4	11.5	15.0	17.5	19.0	34.5
RPM	1800	1790	1780	1765	1755	1745	1740	0
P.F. (%)	6.5	85.5	90.2	90.2	90.2	89.5	88.5	48.0
		47.0	70.0	78.5	83.5	84.5	86.0	

Motor Speed Data

	LR	Pull-Up	BD	Rated	Idle
Speed (rpm)	0	900	1600	1755	1800
Current (Amps)	46.0	41.0	25.0	6.2	2.80
Torque (ft-lb)	34.5	31.0	45.0	15.0	0.00

Information Block

HP	5.0			
Sync. RPM	1800			
Frame	184			
Enclosure	TEAO			
Construction	TTS			
Voltage	30/460#190/38 V			
Frequency	60 Hz			
Design	B			
LR Code letter	J			
Service Factor	1.15			
Temp Rise @ FL	0 °C			
Duty	CONT			
Ambient	40 °C			
Elevation	1,000 feet			
Rotor/Shaft wkt	0.50 Lb-Fe			
Ret Wdg	K1844215 R15			
Sound Pressure @ 1M	62 dBA			
VFD Rating	CONSTANT 20:1			
Outline Dwg	035670-1000			
Conn. Diag	A-EE7308			
Additional Specifications:				
0				
EQUIV CKT (OHMS / PHASE)				
R1	R2	X1	X2	Xm
1.5080	1.1280	3.6910	5.6930	104.3280

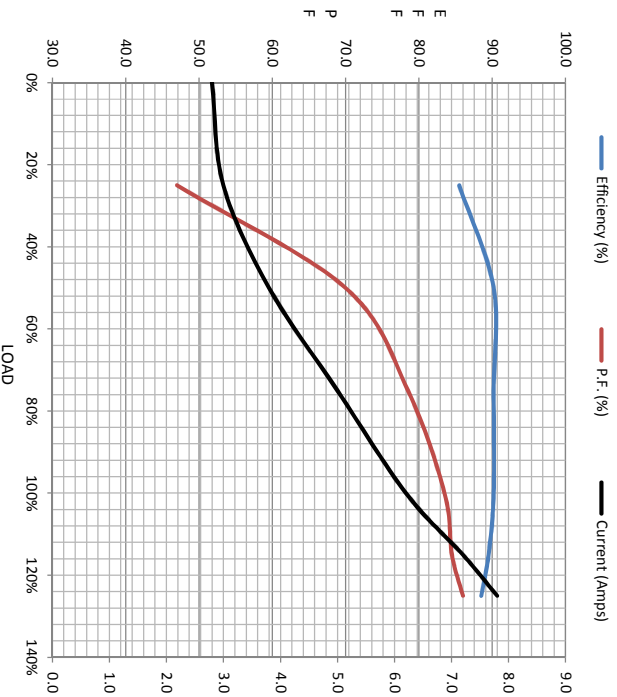

Speed - Torque Curve

